



Badger Meter Europa

Series 250 Metallic tee flow sensors

The series 250 flow sensor features a six bladed impeller design with a proprietary non-magnetic sensing mechanism. The unique impeller is less prone to be fouled by water borne debris. The forward curved shape coupled with the absence of magnetic drag provides improved operation and repeatability even at lower flow rates. This is especially true where the impeller is exposed to metallic or rust particles found in steel or iron pipes. As the liquid flow turns the impeller, a low impedance square wave signal is transmitted with a frequency proportional to the flow rate. The signal can travel up to 600 m between the flow sensor and the receiving unit without the need for amplification. All sensors except irrigation versions are supplied with 20' of 2-conductor 6 m AWG shielded U.L. type PTLC 105°C cable and meet CE standards for noise immunity and susceptibility.



Features

- Sensor electronics easily removed from tee.
- Impeller/bearing/shaft easily replaced in field without changing calibration.
- Two wire sensor. Power and signal transmit on single pair of wires up to the distance of 600 m.
- Digital signal easily interfaced with transmitters, monitors or PLCs.

Applications

- Energy management/building management systems
- Btu submetering systems
- Cooling tower treatment systems
- Condensate return lines

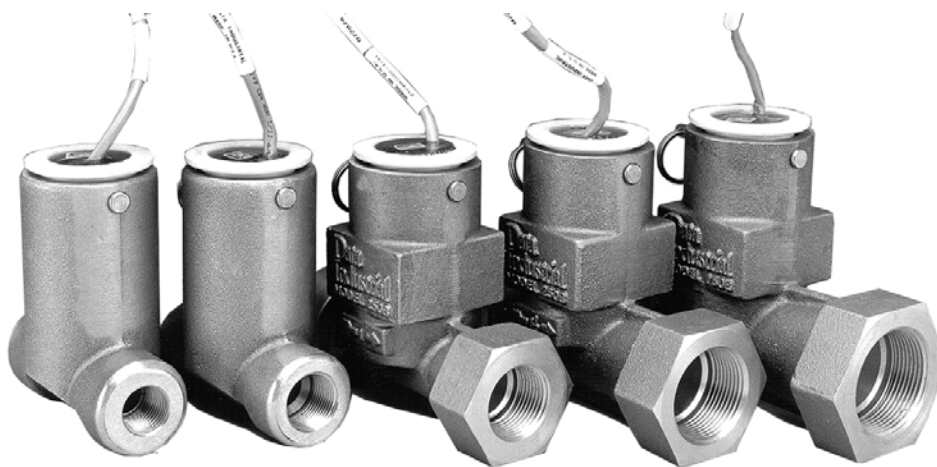

IMP_250_Baureihe_Metall_T-Stück_Durchflusssensoren_Datenblatt_0610_e.doc 06/10

Badger Meter Europa GmbH - Nürtinger Strasse 76 - 72639 Neuffen (Germany)
Tel. +49-7025-9208-0 Fax +49-7025-9208-15 www.badgermeter.de E-mail:badger@badgermeter.de

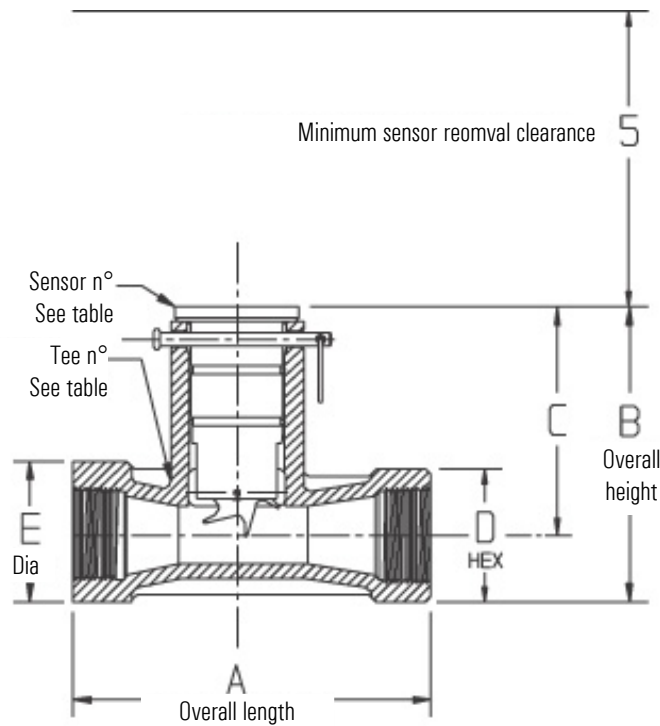

Series n° complete	Sensor n°	Tee n°	NPT	A	B	C	D	E
250B-0.5	See matrix	713168T	1/2-14	4.00	4.67	3.61	N/A	1.63
250B-0.75	See matrix	713169T	3/4-14	4.00	4.67	3.61	N/A	1.63
250B-1.0	See matrix	71940T	1.00-11.5	5.45	4.75	3.75	2.00	2.12
250B-1.25	See matrix	71941T	1.25-11.5	6.06	5.00	3.88	2.25	2.38
250B-1.5	See matrix	711193T	1.50-11.5	6.50	5.19	3.94	2.50	2.62

Specifications

Wetted materials	<ul style="list-style-type: none"> See ordering matrix 						
Tee for 250B	<ul style="list-style-type: none"> Cast valve bronze, UNS C83600 						
Maximum temperature	<ul style="list-style-type: none"> Standard electronics 105°C (221°F) Irrigation electronics 66°C (150°F) 						
Maximum pressure	<table border="1"> <thead> <tr> <th></th> <th>At 24°C</th> <th>At 135°C</th> </tr> </thead> <tbody> <tr> <td>250BR</td> <td>27 bar</td> <td>22 bar</td> </tr> </tbody> </table>		At 24°C	At 135°C	250BR	27 bar	22 bar
	At 24°C	At 135°C					
250BR	27 bar	22 bar					
Recommended design flow range	<ul style="list-style-type: none"> 0,09 to 4,5 m/s 						
Accuracy	<ul style="list-style-type: none"> ± 1.0% of rate 						
Repeatability	<ul style="list-style-type: none"> ± 0.7% over recommended design flow range 						
Linearity	<ul style="list-style-type: none"> ± 0.7% over recommended design flow range 						
Rangeability	<ul style="list-style-type: none"> 60:1 						
Transducer excitation	<ul style="list-style-type: none"> Quiescent current 600 µA @ 8 VDC to 35 VDC max. Quiescent voltage (V_{high}) supply voltage $-(600 \mu A * \text{supply impedance})$ ON state (V_{low}) max. 1.2 VDC @ 40 mA current limit ($150 \Omega + 0.7 \text{ VDC}$) 						
Electrical cable for standard sensor electronics	<ul style="list-style-type: none"> 6 m of 2-conductor 20 AWG shielded U.L. type PTLC wire provided for connection to display or analog transmitter unit. Rated to 105°C. May be extended to a maximum of 600 m with similar cable and insulation appropriate for application. 						
Electrical cable for IR sensor electronics	<ul style="list-style-type: none"> 1,2 m of U.L. style 116666 copper solid AWG 18 wire with direct burial insulation. Rated to 105°C. 						

250 series metal tee sensors ordering matrix (1/2" to 1 1/2")

Example: 2		50	BR	15	0	5	--	0	2	1	1
Style	Cast bronze tee (1/2" to 1.5" only)		50								
Material	Brass/bronze		BR								
Size	0.5"			05							
	0.75"			07							
	1"			10							
	1.25"			12							
	1.5"			15							
Electronics housing	PPS				0						
Electronics	Magnetic					2					
	FM/CSA approved					4					
	Standard					5					
	IR-irrigation					6					
O-ring	Viton®							0			
	EPDM							1			
	Buna N							8			
Shaft	Zirconia ceramic								0		
	Hastelloy C								1		
	Tungsten carbide								2		
	Titanium								3		
	Monel								5		
	316 stainless steel								6		
	Tantalum								7		
Impeller	Nylon									1	
	Tefzel®									2	
Bearing	Pennlon										1
	Tefzel®										2
	Teflon®										3