

# METER

Ultrasonic level transmitter

825B105N

## Technical Data

Housing material: PC or AI / PP wetted part (PVDF for ATEX certified vers.)  
Mechanical installation: 2" GAS M (PP flange DN80 opt.)  
Protection degree: IP67 / IP68 (sensor)  
Electrical connection: Internal push connectors  
Working temperature: -30 ÷ +70°C; +80°C non-continuous  
-20 ° to +60 ° C for ATEX certified vers.  
Pressure: from 0,5 to 1,5 bar (absolute)  
Power supply: 2-wire: 20÷30 Vdc / 4-wire: 24Vdc  
Power consumption: 2-wire max 0,6W / 4-wire max 1,5W  
Analog output: 4÷20mA, max 750ohm (4-wire)  
Relays output: (4-wire only) n°2 3A 230Vac (n.o.)  
Digital communication: MUDBUS RTU for 4-wire vers. (opt.) HART for 2-wire vers.  
Max measure range: max 0.25÷5m; max 0.4÷8m  
[In case of non perfectly reflecting surfaces, the maximum distance value will be reduced]  
Blind distance: 0,25m (5m vers.) / 0,40m (8m vers.)  
Temperature compensation: digital from -30 to 80°C  
Accuracy: ±0,5% (of the measured distance) not better than ±3mm  
Resolution: 1mm  
Calibration: 4 buttons or by HART/MODBUS RTU  
Warm-up: 5 minutes typical  
LCD Display: Plug-in display/keyboard 4 buttons matrix LCD  
Ex-proff: ATEX II 1/2G Ex ia II C T6



## Warranty

Products supplied by SGM LEKTRA are guaranteed for a period of 12 (twelve) months from delivery date according to the conditions specified in our sale conditions document.

SGM LEKTRA can choose to repair or replace the Product.

If the Product is repaired it will maintain the original term of guarantee, whereas if the Product is replaced it will have 12 (twelve) months of guarantee.

The warranty will be null if the Client modifies, repair or uses the Products for other purposes than the normal conditions foreseen by instructions or Contract.

In no circumstances shall SGM LEKTRA be liable for direct, indirect or consequential or other loss or damage whether caused by negligence on the part of the company or its employees or otherwise howsoever arising out of defective goods

## Factory Test Certificate

In conformity to the company and check procedures I certify that the equipment:

**METER**..... Production and check date: .....

Serial n. ....

is conform to the technical requirements on Technical Data and it is made in conformity to the SGM-LEKTRA procedure

Quality Control Manager .....



Process Control and Measurement

# METER - Safety / Mechanical installation

The non intrusive system application is now preferred in the level measurements field. For this reason the **SGM-LEKTRA** developed the **METER** unity to best meet the "GENERAL-PURPOSE" application requests. The **METER** unit offers, together with its compact size, a complete versions range that makes the **METER** very versatile for the most varied applications, including areas with explosion hazard and chemically aggressive environments. **METER** is an ultrasonic level transmitter, temperature-compensated and suitable for connection with **MODBUS RTU** (only 4 wires vers.) or **HART** (option only for 2-wire vers.) acquisition systems. **METER** is a compact unit which in addition to an analog output includes two freely addressable relay (only 4 wires vers.).

- Non-contact level measurements**
- Suitable for liquids and granulates level measurement**
- Integrated digital temperature sensor to compensate the measure**
- HART or MODBUS RTU com. protocol**
- 24Vdc power supply**
- Mechanical protection: IP67 / IP68 (sensor)**
- Output: 1 4÷20mA analog output  
2 relays output (4-wires vers.)**
- ATEX II 1/2G Ex ia II C T6**

## 1. SAFETY

### 1.1 Installation precaution

- a) Installation shall only be performed by qualified personnel and in accordance with local governing regulations.
- b) Make sure that the working temperature is between -30 and +70 ° C, +80 ° C non-continuous (ATEX versions: -20÷+60°C).
- c) Install the transmitter in a its physical characteristics and housing/sensor construction materials compatible environment.
- d) The transmitter must be used safety warnings observance.
- e) Improper transmitter use would cause serious damage to people, to the product and connected equipment.

## 2. INSTALLATION

### 2.1 MECHANICAL DIMENSIONS

The METER transmitter has the 2 "GAS M threaded, equipped with 2" BSP/ PP fixing bolt. DN80 PN6 UNI 1092-1/PP flange is available (optional accessory).

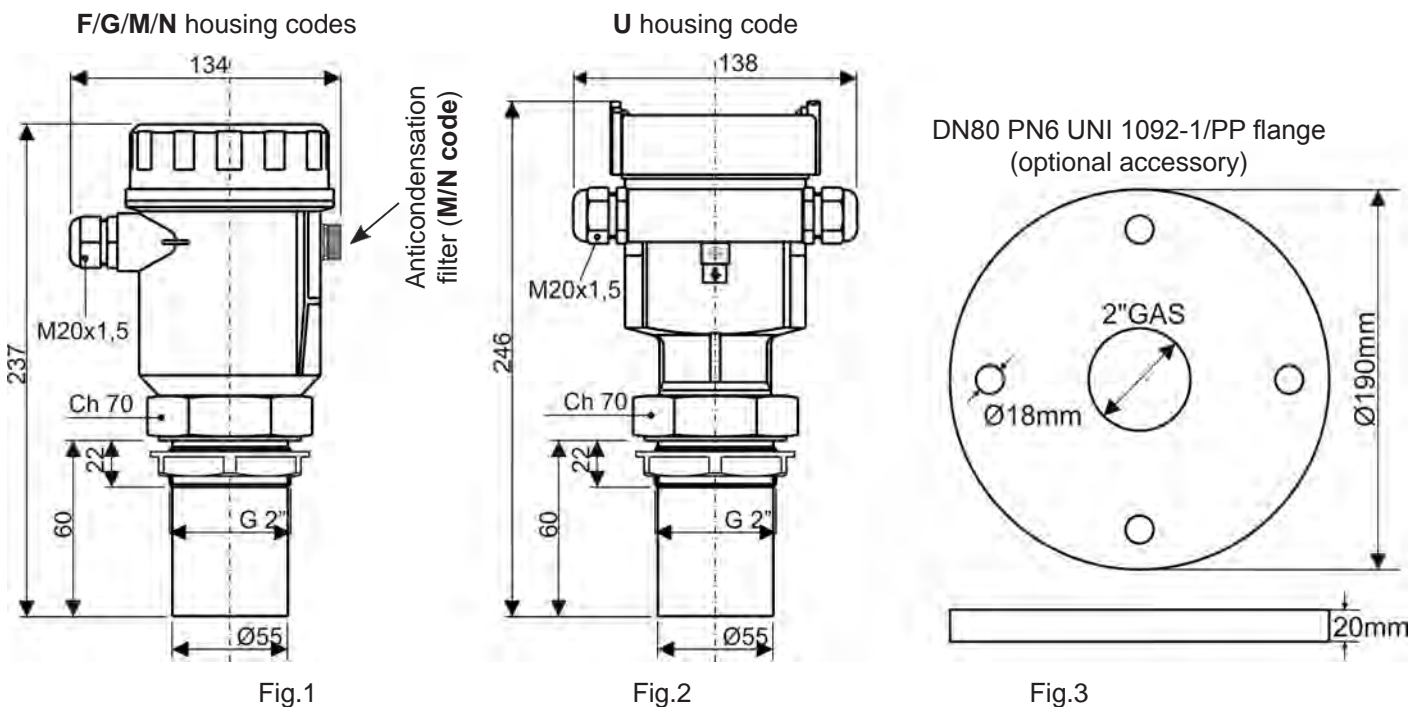

# METER - Mechanical installation

## 2.2 Mounting examples

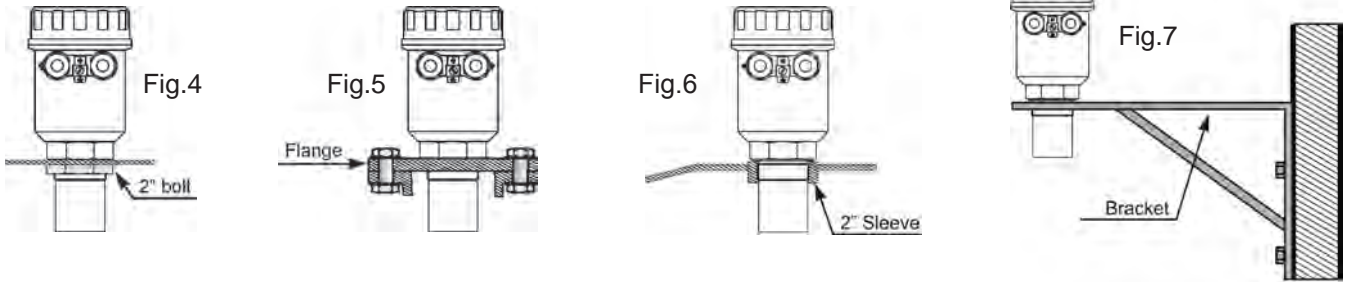

## 2.3 Mounting precautions

### 2.3.1 Mounting position (Fig.8)

- With cambered roof, Do not install the sensor in the tank center (b). Leave a 300mm minimum distance between the sensor and the tank smooth wall (d).
- Use a protective cover to protect the sensor from weather and direct sunlight (c).
- Do not install the sensor near the load zone (a).
- Make sure that in the sensor emission beam (lobe "α") there are no obstacles (f,s) that can be intercepted as level.
- Make sure that there is not foam presence on the product surface to be measured

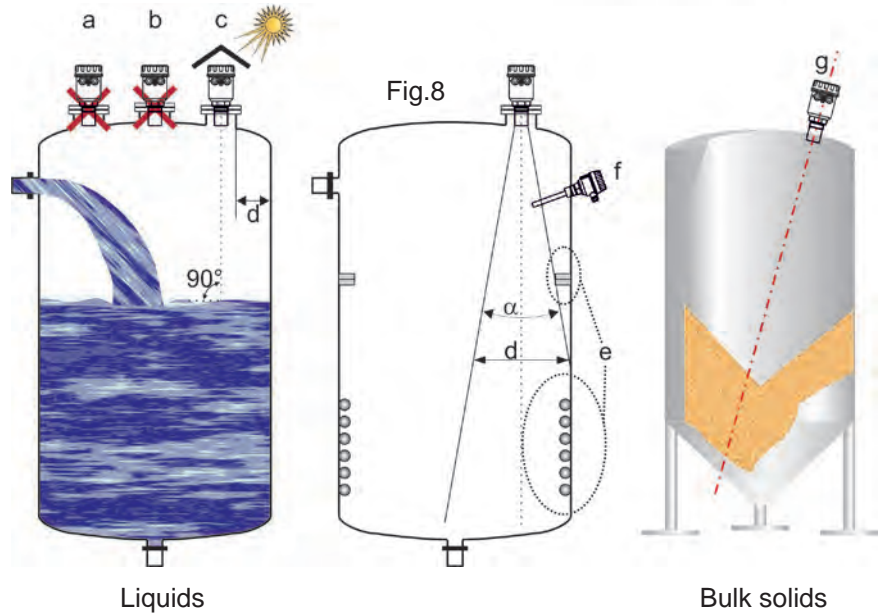

	Lobo "α"	L	d
METER 5m	10°	5m	1m (5m)
METER 8m	10°	8m	1.6m (8m)

Tab.1

### 2.3.1 Blind distance

During installation is important to remember that in the sensor vicinity there is a blind zone (or **BLIND DISTANCE**) of 0.25m (for 5m max **METER** range) or 0.4m (for 8m max **METER** range) where the sensor can not measure.

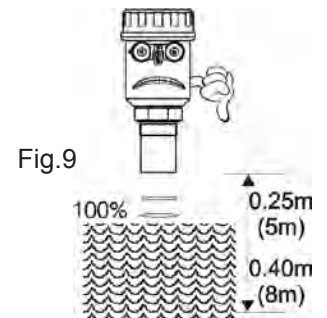

### 2.3.2 Installation in nozzle

Installing the **METER** sensor in a nozzle (see fig.10), make sure the sensor bottom protrudes at least 10 mm from the bottom nozzle

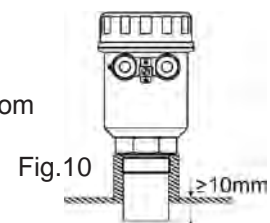

**METER** can be installed in an extension pipe (see Figure 11) to turn away the sensor from the maximum level point. The extension pipe must be flat and without joints (welds, etc..), also, the pipe terminal part must be cut at 45° and with the borders without burr.

METER 5m		METER 8m	
D (mm)	Lmax(mm)	D (mm)	Lmax(mm)
57	80	80	240
80	240	100	300
100	300		

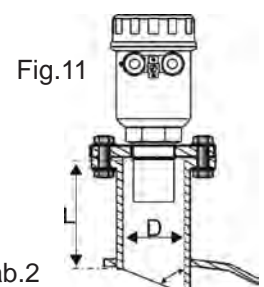

Tab.2

## 2.3.4 Reference pipe installation

Disturbing factors that may influence the level measurement in liquids, as for example:

- foam presence on the product surface (Fig.12)
- internal structures presence in the tank (Fig.13)
- presence on the liquid surface of floating bodies (Fig.14) can be avoided with the use of level measurement inside of pipes (by-pass pipe or calm pipe with 57mm min. diameter)

The pipe must have a length greater or equal than the empty distance, also, must have some of vent holes (Fig. 14-A) to allow the pipe regular filling and emptying.

In the programming menu, to the **"PRODUCT"** parameter, must select the **"LIQUID PIPE"** option (see page 9 or 15)

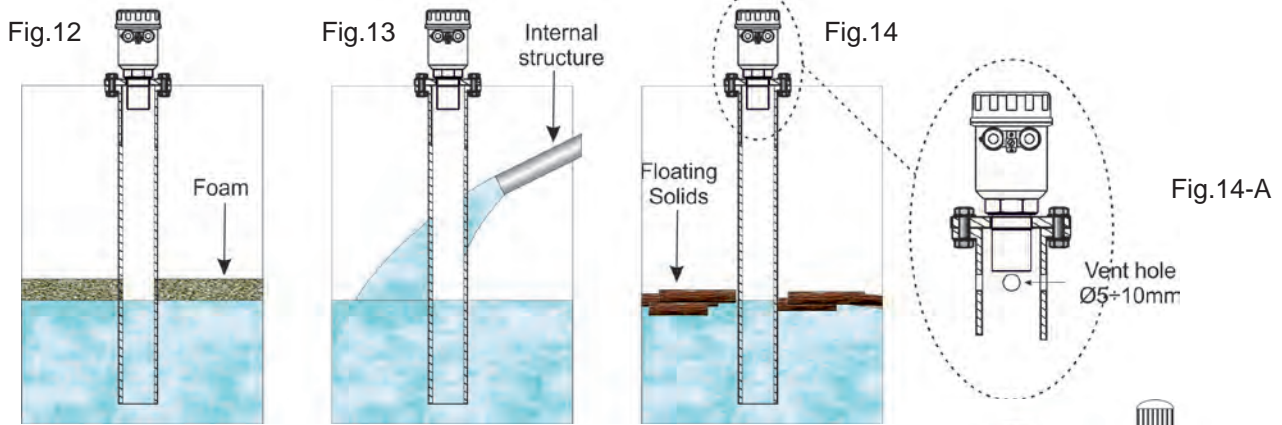

## 2.3.5 Agitators presence

The level measurement is possible thanks to the **Auto-Tuned** statistical filter. Should rarely need to adjust the filter setting by editing 2 **METER** sensor programming parameters:

- **FILTER**; this parameter is present in the **Quick Setup** menu (page 9) and in the Advanced Configuration **"SETUP"** menu (page 16); increasing the parameter value, decreases the sensor sensitivity to the level measurement sudden variations.
- **F-WINDOW**; this parameter is present in the Advanced Configuration **"SERVICE"** menu (page 26); decreasing the parameter programmed value, increases the sensor immunity to false echoes.



## 2.3.6 Mechanical installation accessories

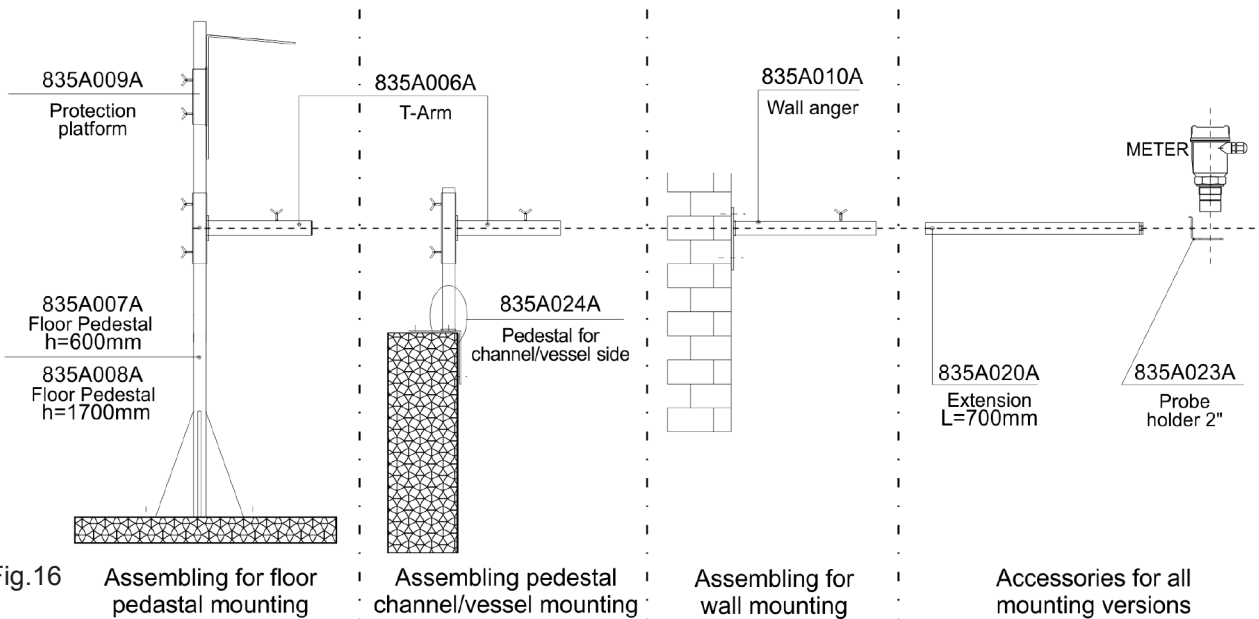

## 3. CONNECTIONS

### 3.1 Wiring

- 1) Separate the engine control cables or power cables from the **METER** connection cables..
- 2) Open the cap by unscrewing.
- 3) Lead the cables into the transmitter through the glands.
- 4) Do not use sleeves terminals, because they might interfere with the **VL601** module insertion
- 5) Close the cap and tighten the cable glands.

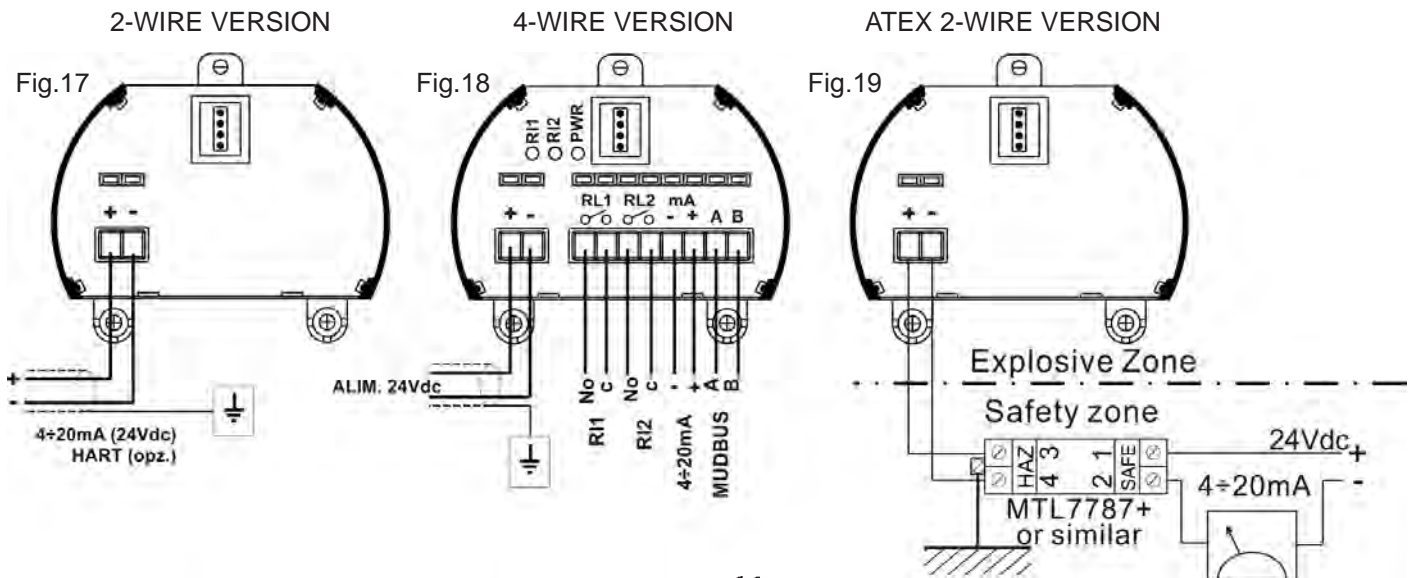

The immunity to electromagnetic interference complies with **CE** Directives

### 3.2 Humidity infiltrations

To avoid the humidity infiltration inside the housing is recommended:

- for electrical connections, use a cable with a 6÷12mm outer diameter and fully tighten the M20 cable gland
- fully tighten the cap
- position the cable so that it forms a downward curve at the M20 output (Fig. 20); in this way the condensation and/or rain water will tend to drip from the curve bottom

For installations with a strong humidity/vapor presence the version with the optional anti-condensation filter (cod.M/N) is available

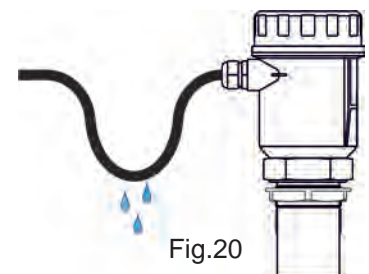

## 4. CONFIGURATION MODES

The **METER** have 2 configuration/calibration modes:

- via digital communication:
  - via **MODBUS RTU**, by PC, for 4-wires versions
  - via **HART**, by Hand-Held or PC, for 2-wires versions (optional)
- via **VL601** programming module

### 4.1 Via MODBUS RTU

#### 4.1.1 4-wires METER; MODBUS RTU PC connection (fig.21)

- 1) METER4\_\_\_\_ or METER8\_\_\_\_ (1) with MODBUS RTU communication protocol
- 2) USB/RS485 interface module, cod.694A004A
- 3) MODBUS RTU communication S/W, cod.010F105A (3), for METER transmitter

With this software is possible:

- connect, by selecting the UID address, the METER transmitters in MODBUS RTU network
- read on your PC monitor all measures in reading and METER operation data
- programming all METER configuration parameters
- storing on files, data logger function; METERmeasures in reading and operating states

# METER - Configuration

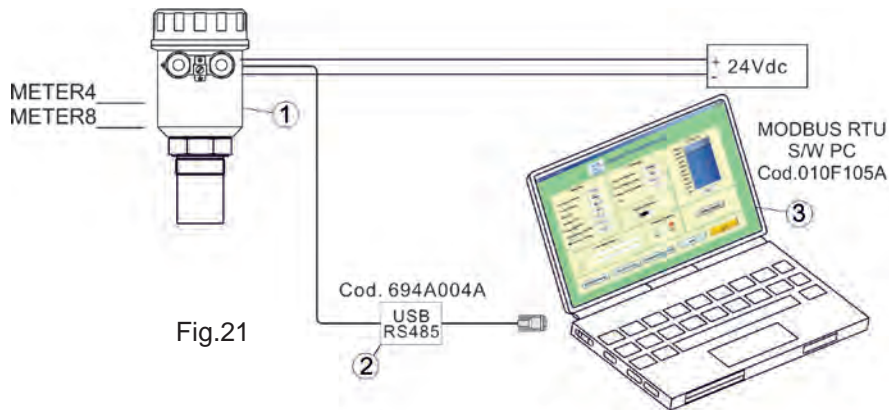

Fig.21

## 4.2 Via HART

### 4.2.1 2-wires METER; HART Hand Held connection or HART PC/MODEM (fig.23)

- 1) METER-\_\_\_, METER0 \_\_\_, METER2\_\_\_, METER7\_\_\_, with HART communication protocol
- 2) 250ohm resistance
- 3) HART MODEM
- 4) HART communication S/W, cod.010E105A (for PC HART MODEM only)
- 5) HART HAND-HELD

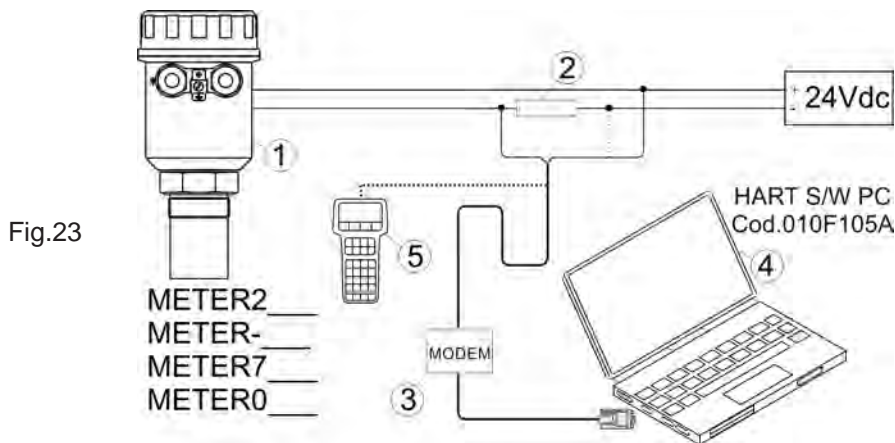

Fig.23

## 4.3 via VL601 configuration

The **VL601** programming module can be mounted and removed from the **METER** without affecting the unit operation. Unscrewing the cap, the **VL601** module can be mounted (by clockwise rotation until it clicks) or dismantled (by rotation counterclockwise) as shown in Fig.21. The **VL601** module is equipped with matrix LCD.

))) displayed at the bottom indicates the correct echo signal reception

! displayed at the top alerts that there is a generic error; press  to show the message that indicates the present error type. The METER returns automatically to RUN mode.











Fig.21

## METER - Configuration

The **VL601** program module has 4 buttons (fig. 24) which allow to perform all operational, control and programming instrument functions.





In the configuration menus, is possible:

- Submenus and parameters access; press  to select and press  to access.
- Parameter options choice: Press  to select the option and press  to store the option.  
Press  to exit without storing
- Configure the parameter values; in some parameters the configuration is done by setting a value (eg., in the **SET DISTANCE 4mA** parameter is possible to change the the corresponding distance value, in mm): press  to select the digit to be modified (the digit is highlighted in **inverse**), press  to change the highlighted digits number, press  to save the set value and exit automatically. Press  to exit without storing .





In the display top right, during the settings, there is always a number, eg. "1.2". This number is the menu or parameter index that's displayed. The menu structure is represented on page 8 and on pages 13÷14.



Fig.24

-  - Configuration access  
- Options confirmation  
- Parameters values confirmation
-  - Parameters values selection  
- Parameters scroll
-  - Parameters values modification
-  - Exit configuration  
- Back to previous menu  
- Eco map (from RUN mode)

### With the VL601 module is possible to access two configuration modes for the METER setting:

- QUICK START - Menu with easy access for quick basic parameters configuration.  
To access: from "RUN" mode press  to the quick setup menu mode access,  to exit
- ADVANCED CONFIGURATION - Full menu with access to all parameters, including functional parameters.  
*It is recommended to carefully read the complete documentation before accessing.*  
To access: from "RUN" mode, holding down , press  to the advanced configuration mode access,  to exit

**WARNING!** - The documentation provided with the METER contain the most frequently used indications. If it's necessary refer to the full manual, it can be downloaded from our website [www.sgm-lektra.com](http://www.sgm-lektra.com) , in the products section.

## 5. QUICK START MODE

From "RUN" mode press **ENTER** to access the Quick Setup menu



Select the parameters by moving the cursor with **←** and **→**, and confirm with **ENTER**; press **ESC** to exit

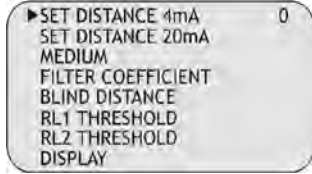

### 5.1 Quick Setup menu structure

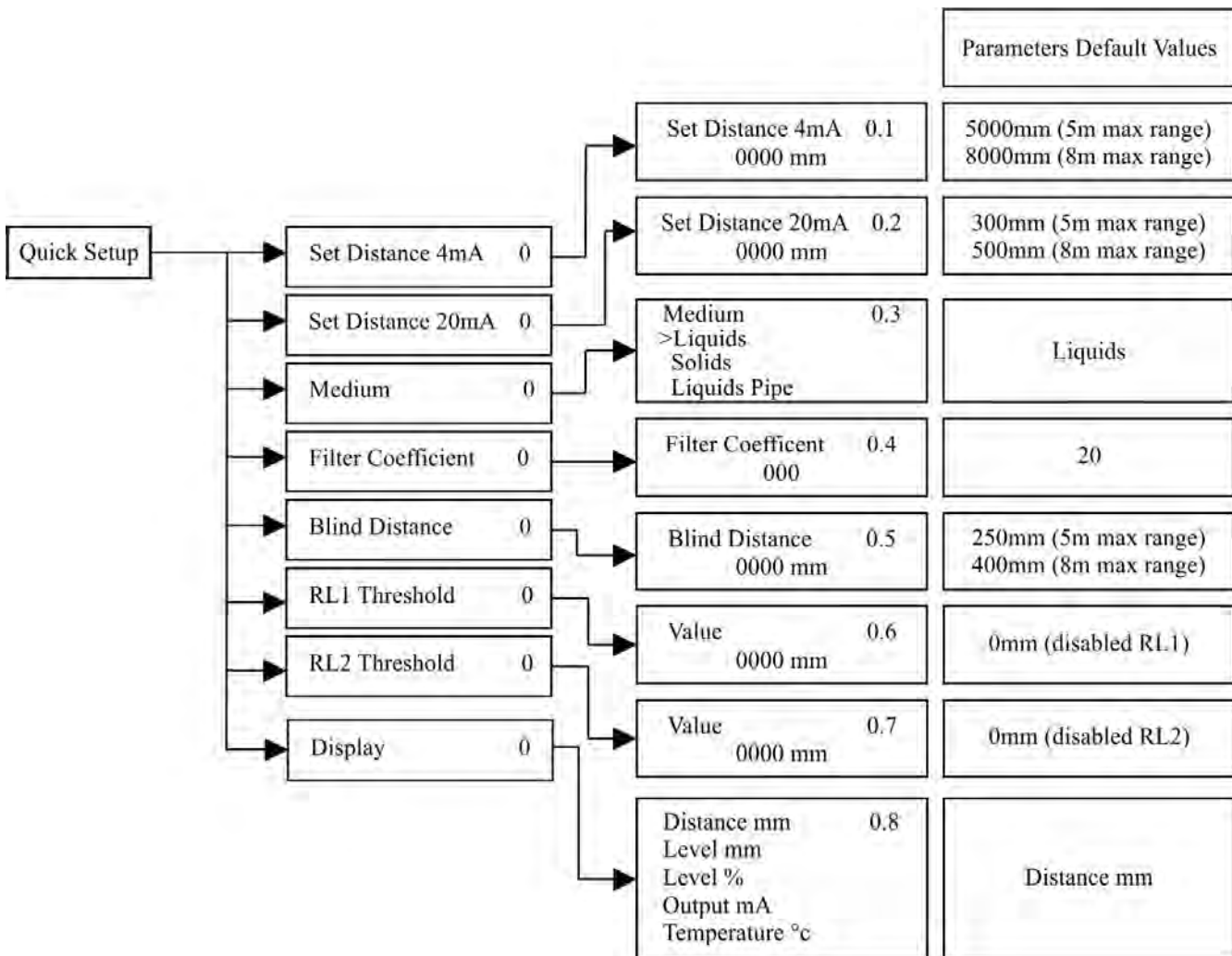



## 5.2.1 SET DISTANCE 4mA

Press **ENTER** to display the distance value associated with 4mA output.

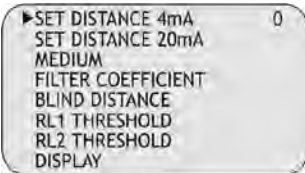

Use **↓** and **↑** to modify that value; in the Fig.25 example, the 4mA distance is 3500mm. Press **ENTER** to confirm.



## 5.2.2 SET DISTANCE 20mA

Press **ENTER** to display the distance value associated with 20mA output.

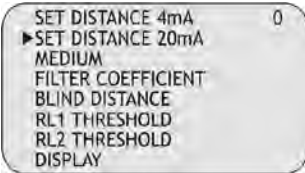

Use **↓** and **↑** to modify that value; in the Fig.25 example, the 20mA distance is 500mm. Press **ENTER** to confirm.



## 5.2.3 MEDIUM

Press **ENTER** to display the previous setting

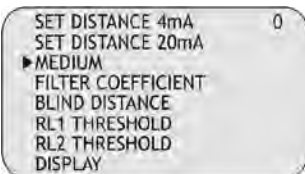

Press **↓** to select the medium type. Press **ENTER** to confirm. In fig.26 product selection example.

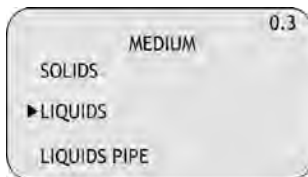

## 5.2.4 FILTER COEFFICIENT

Press **ENTER**. Increasing the value slows down the sensor response speed.

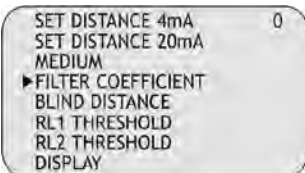

Use **↓** and **↑** to modify the value. Input a value from 1 to 99. Press **ENTER** to confirm. In fig.27 value choice example.



## 5.2.5 BLIND DISTANCE

Press **ENTER**. The **BLIND ZONE** is used to avoid undesired measures near to the transmitter

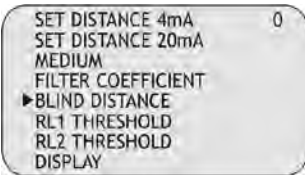

Use **↓** and **↑** to modify the value. Press **ENTER** to confirm. The minimum value is 250mm (5m max vers.) or 400mm (8m max vers.).

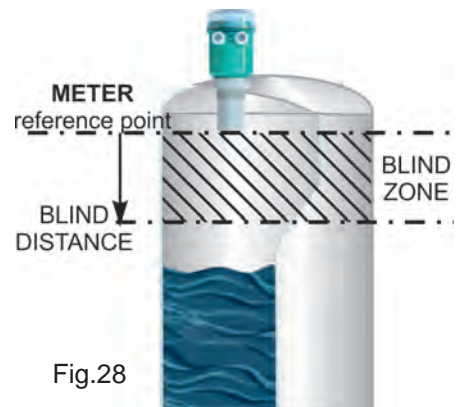
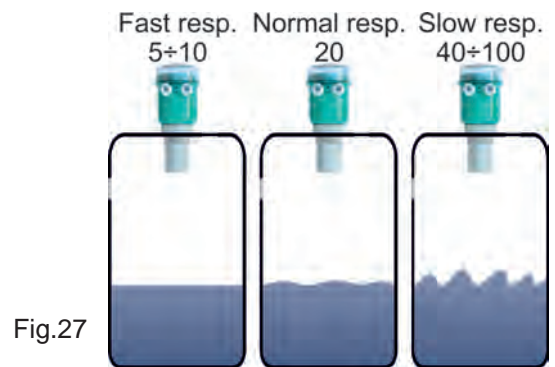
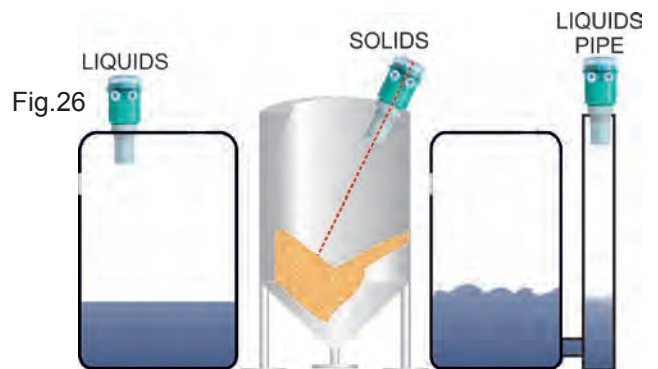
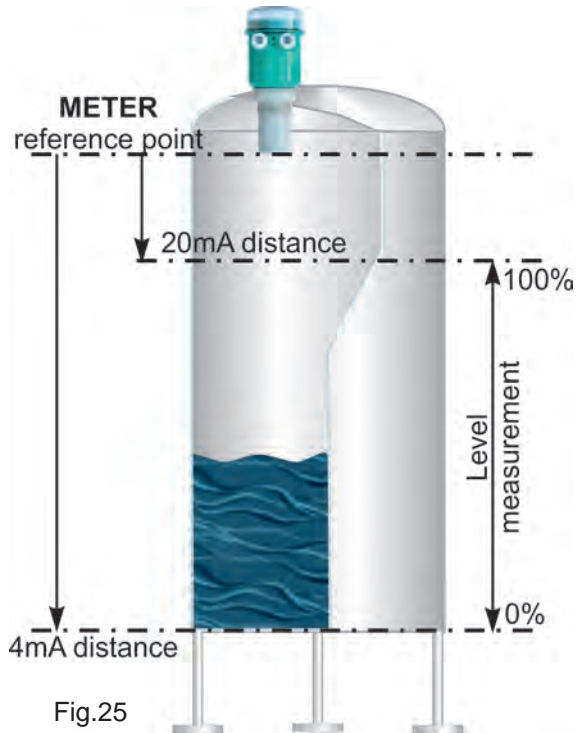

# METER - Quick Start

## 5.2.6 RL1 THRESHOLD

Press **ENTER** to display the previous setting. Set the distance from the sensor



Use **←** and **→** to modify the value; in the Fig.29 example the RL1 max. level threshold distance is 700mm. Press **ENTER** to confirm.

**NB**-RL1 inactive with 0000mm

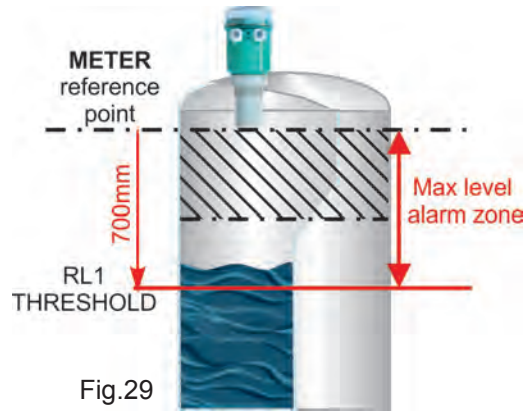

When confirming with the **ENTER** button the maximum level threshold value storage, in the example 700m (figures 29 and 30), the **METER** activates RL1 with the following default settings for level alarm threshold:

- 1) MIN / MAX = MAX; maximum level alarm
- 2) DELAY = 0 sec.; no switching delay
- 3) SECURITY = YES; relay de-energized, and contact open, during the maximum level alarm
- 4) ENABLE / DISABLE = ENABLE; alarm threshold function enabled

To change these relay settings is necessary to access the advanced setup menu (pag.16) and any subsequent changes to the RL1 threshold value not affect the relay custom settings.

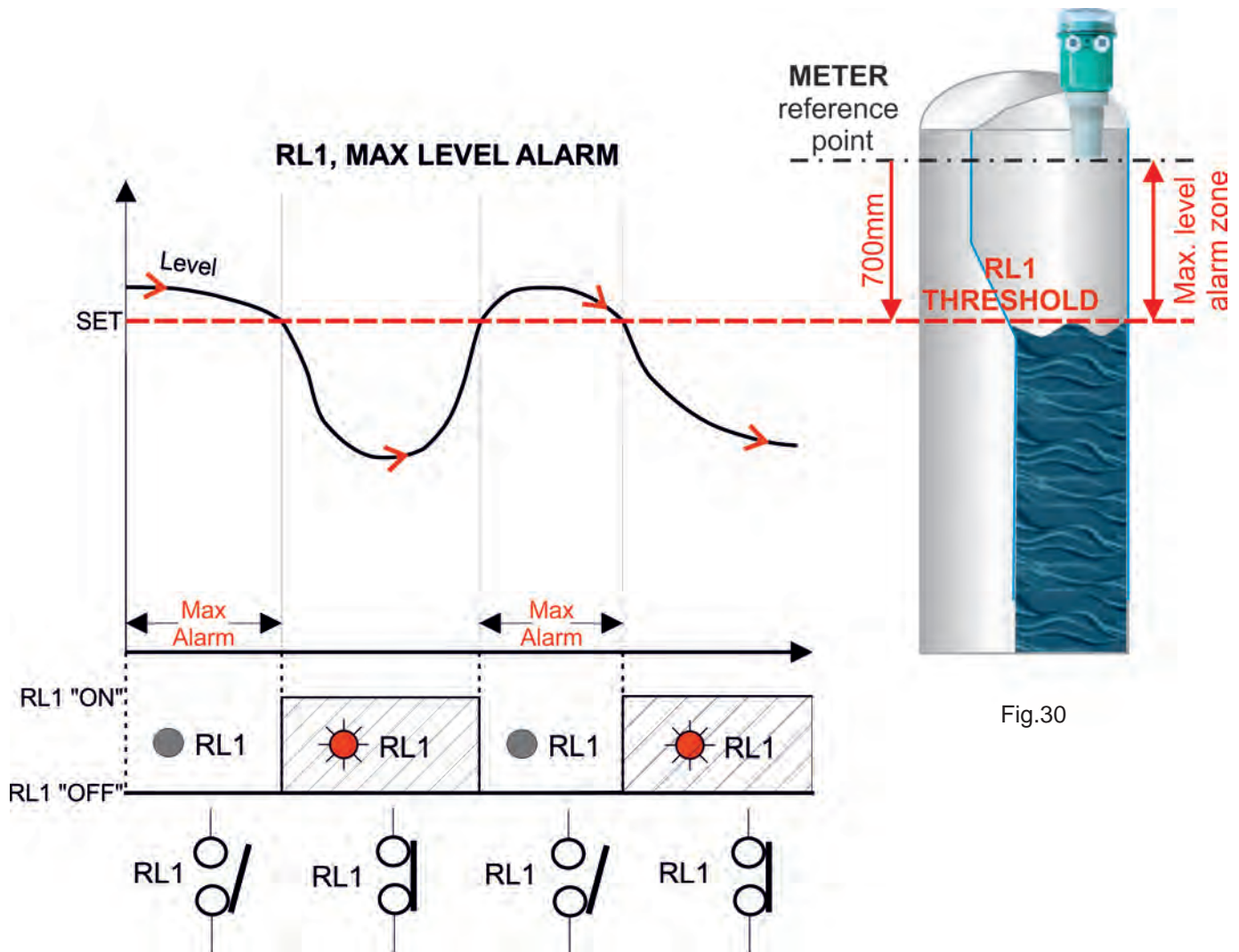
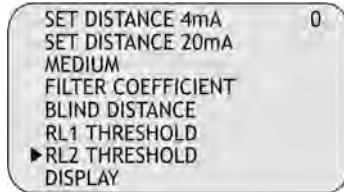

Fig.30

# METER - Quick Start

## 5.2.7 RL2 THRESHOLD

Press **ENTER** to display the previous setting. Set the distance from the sensor



Use **↓** and **↑** to modify the value; in the Fig.31 example the RL2 min. level threshold distance is 3000mm.

Press **ENTER** to confirm.

**NB**-RL2 inactive with 0000mm

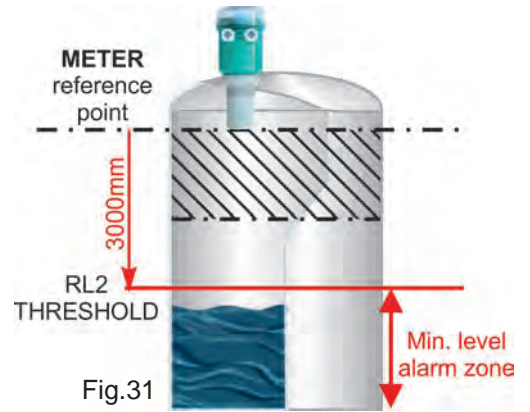

When confirming with the **ENTER** button the maximum level threshold value storage, in the example 3000mm (figures 31 and 32), the **METER** activates RL2 with the following default settings for level alarm threshold:

- 1) MIN / MAX = MIN; minimum level alarm
- 2) DELAY = 0 sec.; no switching delay
- 3) SECURITY = YES; relay de-energized, and contact open, during the maximum level alarm
- 4) ENABLE / DISABLE = ENABLE; alarm threshold function enabled

To change these relay settings is necessary to access the advanced setup menu (pag.16) and any subsequent changes to the RL2 threshold value not affect the relay custom settings.

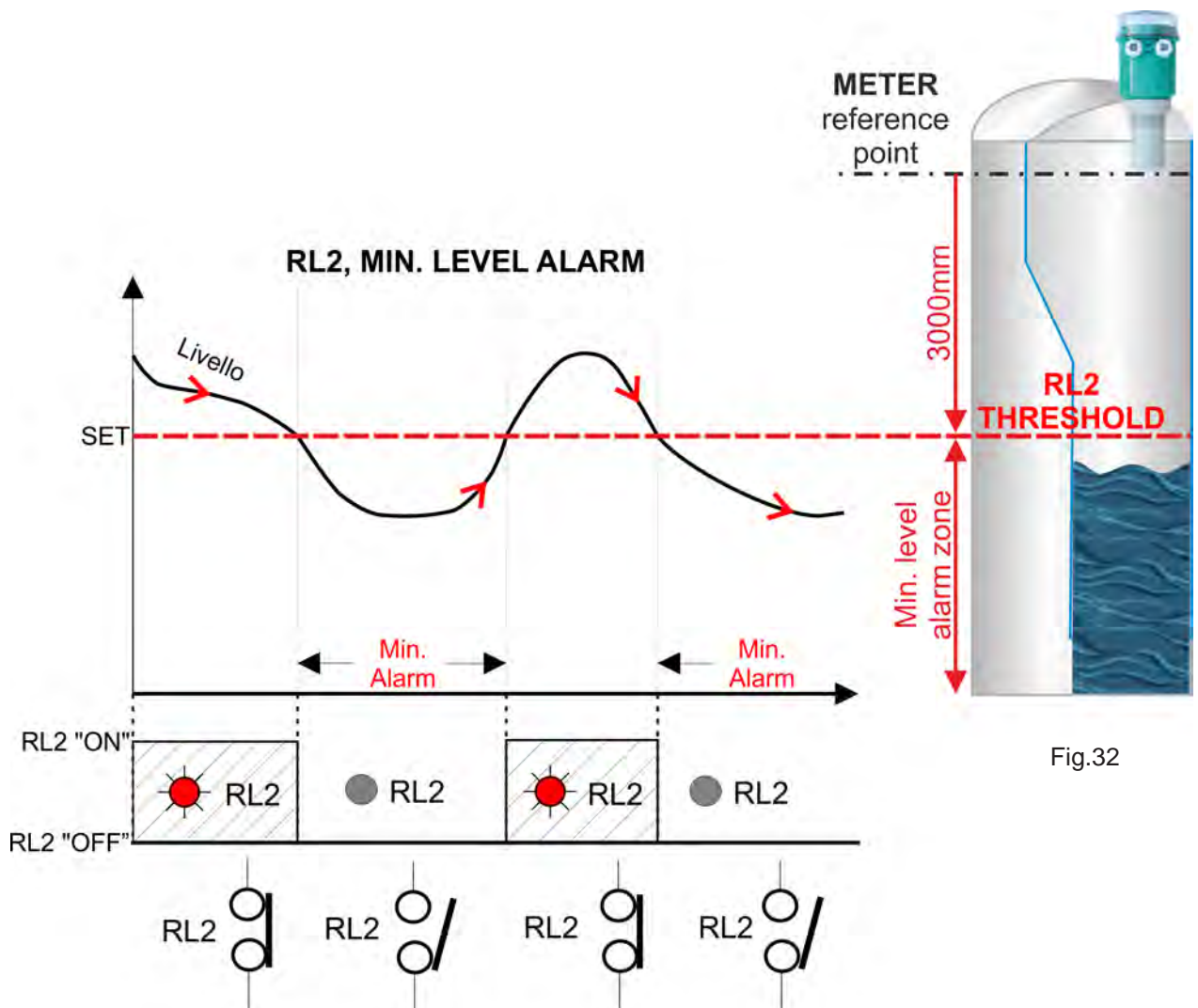

# METER - Quick Start

## 5.2.8 DISPLAY

Press to access the settings change.



With the button is possible to select the data to display  
Press to confirm.

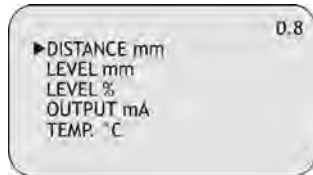

Fig.33

## 5.2 ECHO MAP

Pressing the **BK**, from RUN mode, to access directly to the echoes digital map display, which are in METER receiving (Fig.34).

This function is useful for:

- properly orient the transducer pointing.
- verify the echoes in acquisition correctness.
- identify any false echo signals that may cause measurement errors.

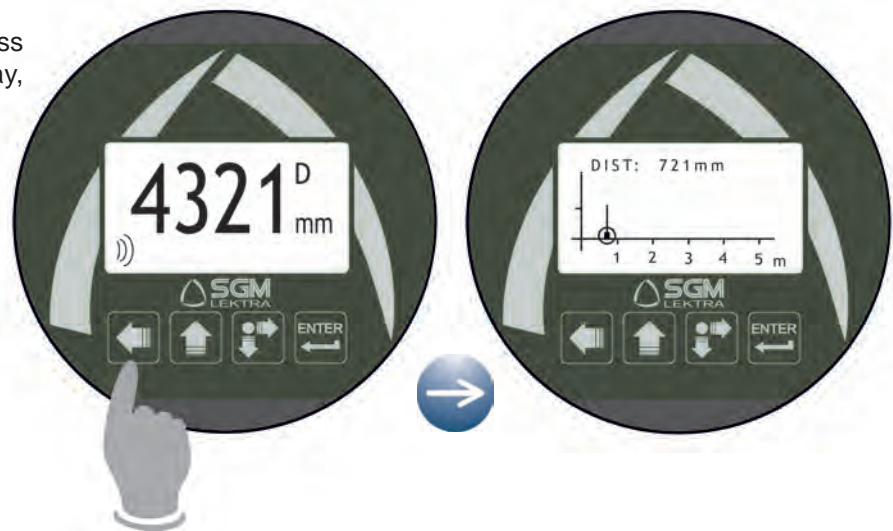

Fig.34

