



**RPL58**  
Radar level transmitter

Continuous level measurement without contact for liquids, pastes and slurries

Range 10 m

Process pressure 3 bar

2 / 4 wires technology

Pulse Radar at 26 GHz (K-band)

ATEX

RPL58 is a radar sensor for bulk solids continuous measurement. Suitable for application in silos and storage in large sheds, also in hard working conditions. Suitable for level measurement in tanks with 1 1/2 "G threaded or flanged connection. The different antenna models and the wide temperature and pressure range make the RPL58 radar sensor the optimal solution for nearly all kinds of application..

**Technical Feature**

**Frequency**

K group (26GHz)

**Housing / Antenna material**

aluminum / SS316L; PTFE

**Mechanical installation**

threaded G1 1/2 ; flange DN 50; 80; 100; 150; 200; 250

**IP rating**

IP67/IP68 (Sensor)

**Electrical connection**

Terminals

**Working temperature**

-40° ÷ +130°C / -60° ÷ +250°C

**Pressure**

-1 a 40 bar

**Power supply**

24Vdc; 230Vac

**Certification**

ATEX

**Analog output**

4÷20mA

**Digital communication**

HART / MODBUS

**Measure range**

70 mt

**Accuracy**

±15mm

**Resolution**

1mm.

**Calibraton**

4 buttons or via HART / MODBUS

**Warm up**

5 minutes

**Display**

Plug-in display/keyboard 4 buttons matrix LCD

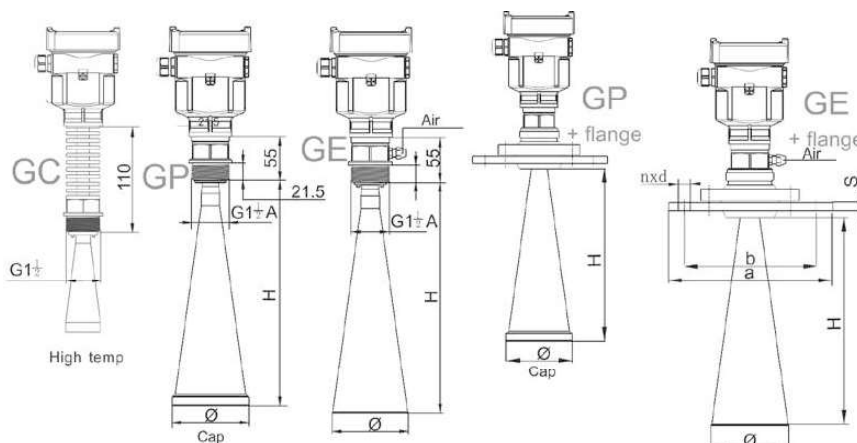

(Cod.)	ΦAnt.	H	An.Mat.
(B)	Φ48	140	SST316
(C)	Φ78	227	SST316
(H)	Φ98	288	SST316
(J)	Φ123	620	SST316
(M)	Φ98 + Cap	300	SST316
(P)	Φ123 + Cap	625	SST316



**RPL58** Radar level transmitter  
 Micro-waves pulse 26GHz group K  
 For bulk solids and powders storage or process applications  
 Max distance: 70m  
 Accuracy: ±15mm  
 Process pressure: -1+40bar

Version	
<b>I</b>	ATEX II 1 G/D Ex ia IIC T6...3 Ga / Ex ia IIIC T76°C...T146°C Da - only with G housing and B electronic
<b>P</b>	Standard
Antenna shape / Material	
<b>B</b>	Horn antenna Ø48mm / SS316L
<b>C</b>	Horn antenna Ø78mm / SS316L
<b>H</b>	Horn antenna Ø98mm / SS316L
<b>J</b>	Horn antenna Ø123mm / SST316L
<b>M</b>	Horn antenna Ø98mm / SST316L with PTFE cap
<b>P</b>	Horn antenna Ø123mm / SST316L with PTFE cap
<b>Q</b>	Parabolic horn Ø198mm / SST316L
<b>R</b>	Parabolic horn Ø246mm / SST316L
Process connection / Material	
<b>GC</b>	Thread G 1" ½ with cooling fin / SS316L (-60°+ +250°C)
<b>GE</b>	Thread G 1" ½ / SS316L with blowing in connection (-40°+ +130°C - 0+5bar)
<b>GP</b>	Thread G 1" ½ / SS316L (-40°+ +130°C)
<b>ZZ</b>	Special
Additional flange (DN / Material)	
<b>FA</b>	DN50 / PP
<b>FB</b>	DN50 / PTFE
<b>FC</b>	DN50 / SS316
<b>GA</b>	DN80 / PP
<b>GB</b>	DN80 / PTFE
<b>GC</b>	DN80 / SS316
<b>HA</b>	DN100 / PP
<b>HB</b>	DN100 / PTFE
<b>HC</b>	DN100 / SS316
<b>HE</b>	Aiming device DN100 / SS316
<b>JA</b>	DN150 / PP
<b>JB</b>	DN150 / PTFE
<b>JC</b>	DN150 / SS316
<b>JE</b>	Aiming device DN150 / SS316
<b>KA</b>	DN200 / PP
<b>KB</b>	DN200 / PTFE
<b>KC</b>	DN200 / SS316
<b>KE</b>	Aiming device DN200 / SS316
<b>LA</b>	DN250 / PP
<b>LB</b>	DN250 / PTFE
<b>LC</b>	DN250 / SS316
<b>LE</b>	Aiming device DN250 / SS316
<b>OO</b>	None
<b>ZZ</b>	Special
Seal / Process temperature	
<b>2</b>	Viton / -40+130°C
<b>3</b>	Kalrez / -60+250°C
Electronic preamplifier	
<b>A</b>	None
<b>B</b>	4+20mA HART (2-wire); 24Vdc - compulsory for ATEX version
<b>C</b>	4+20mA HART (4-wire); 24Vdc
<b>D</b>	4+20mA HART (4-wire); 230Vac
<b>R</b>	10+30 Vdc MODBUS RTU
Housing / Housing protection / Antenna protection	
<b>D</b>	Aluminum 2 chambers (for 4-wire versions) / IP67 / IP68
<b>G</b>	SS316L / IP67 / IP68 - compulsory for ATEX version
<b>U</b>	Aluminum with transparent cap / IP67 / IP68
<b>Z</b>	Special
Cable entry	
<b>M</b>	M20x1,5
Keyboard/display programming module VL602	
<b>A</b>	Yes
<b>X</b>	No